

# HYDROTOOLS™

By **SWIMLINE®**

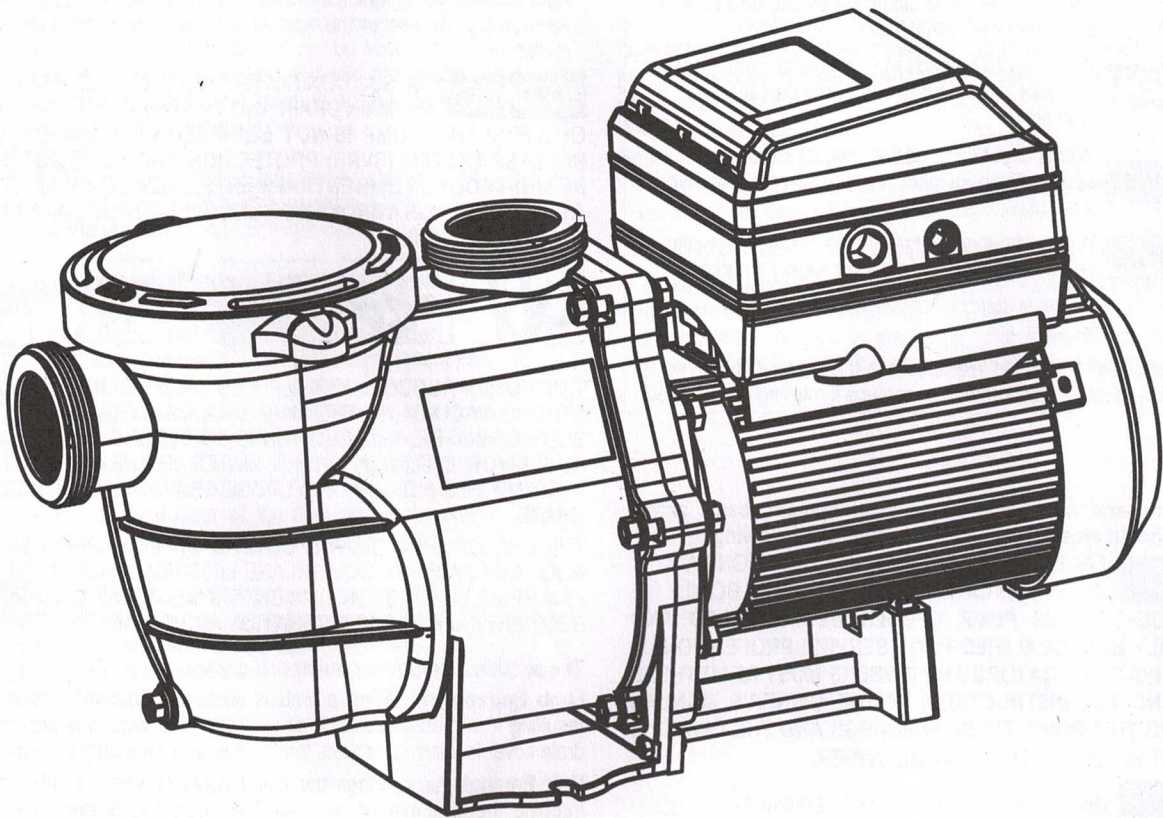

OWNERS MANUAL  
**VARIABLE SPEED PUMPS 1.5HP/3HP**

#73150 / #73300



# IMPORTANT SAFETY INSTRUCTIONS



## IMPORTANT NOTICE

This guide provides installation and operation instructions for this pump. Consult us with any questions regarding this equipment.

**Attention Installer:** This guide contains important information about the installation, operation and safe use of this product. This information should be given to the owner and/or operator of this equipment after installation or left on or near the pump.

**Attention User:** This manual contains important information that will help you in operating and maintaining this product. Please retain it for future reference.

### READ AND FOLLOW ALL INSTRUCTIONS SAVE THESE INSTRUCTIONS



This is the safety alert symbol. When you see this symbol on your system or in this manual, look for one of the following signal words and be alert to the potential for personal injury.

#### **⚠ DANGER**

Warns about hazards that can cause death, serious personal injury, or major property damage if ignored.

#### **⚠ WARNING**

Warns about hazards that may cause death, serious personal injury, or major property damage if ignored.

#### **⚠ CAUTION**

Warns about hazards that may or can cause minor personal injury or property damage if ignored.

#### **NOTE**

Indicates special instructions not related to hazards.

Carefully read and follow all safety instructions in this manual and on equipment. Keep safety labels in good condition; replace if missing or damaged.

When installing and using this electrical equipment, basic safety precautions should always be followed, include the following:

#### **⚠ DANGER**

FAILURE TO FOLLOW ALL INSTRUCTIONS AND WARNINGS CAN RESULT IN SERIOUS BODILY INJURY OR DEATH. THIS PUMP SHOULD BE INSTALLED AND SERVICED ONLY BY A QUALIFIED POOL SERVICE PROFESSIONAL. INSTALLERS, POOL OPERATORS AND OWNERS MUST READ THESE WARNINGS AND ALL INSTRUCTIONS IN THE OWNER'S MANUAL BEFORE USING THIS PUMP. THESE WARNINGS AND THE OWNER'S MANUAL MUST BE LEFT WITH THE POOL OWNER.

#### **⚠ WARNING**

Do not permit children to use this product.

#### **⚠ CAUTION**

This pump is for use with permanent swimming pools and may also be used with hot tubs and spas if so

marked. Do not use with storable pools. A permanently-installed pool is constructed in or on the ground or in a building such that it cannot be readily disassembled for storage. A storable pool is constructed so that it is capable of being readily disassembled for storage and reassembled to its original integrity.

## General Warnings

- Never open the inside of the drive or motor enclosure. There is a capacitor bank that holds a 230 VAC charge even when there is no power to the unit.
- The pump is not submersible.
- The pump is capable of high flow rates; use caution when installing and programming to limit pumps performance potential with old or questionable equipment.
- Code requirements for electrical connection differ from country to country, state to state, as well as local municipalities. Install equipment in accordance with the National Electrical Code and all applicable local codes and ordinances.
- Before servicing the pump; switch OFF power to the pump by disconnecting the main circuit to the pump.
- This appliance is not intended for use by persons (including children) of reduced physical, sensory or mental capabilities, or lack of experience and knowledge, unless they have been given supervision or instruction concerning the use of the appliance by a person responsible for their safety.

#### **⚠ DANGER**

SUCTION ENTRAPMENT HAZARD: STAY OFF THE MAIN DRAIN AND AWAY FROM ALL SUCTION

OUTLETS! THIS PUMP IS NOT EQUIPPED WITH SAFETY VACUUM RELEASE SYSTEM (SVRS) PROTECTION AND DOES NOT PROTECT AGAINST BODY OR LIMB ENTRAPMENTS, DISEMBOWELMENTS (WHEN A PERSON SITS ON A BROKEN OR UNCOVERED POOL DRAIN) OR HAIR ENTANGLEMENTS.



THIS PUMP PRODUCES HIGH LEVELS OF SUCTION AND CREATES A STRONG VACUUM AT THE MAIN DRAIN AT THE BOTTOM OF THE BODY OF WATER. THIS SUCTION IS SO STRONG THAT IT CAN TRAP ADULTS OR CHILDREN UNDER WATER IF THEY COME IN CLOSE PROXIMITY TO A DRAIN OR A LOOSE OR BROKEN DRAIN COVER OR GRATE.

THE USE OF UNAPPROVED COVERS OR ALLOWING USE OF THE POOL OR SPA WHEN COVERS ARE MISSING, CRACKED OR BROKEN CAN RESULT IN BODY OR LIMB ENTRAPMENT, HAIR ENTANGLEMENT, BODY ENTRAPMENT, Evisceration AND/OR DEATH.

#### The suction at a drain or outlet can cause:

**Limb Entrapment:** When a limb is sucked or inserted into an opening resulting in a mechanical bind or swelling. This hazard is present when a drain cover is missing, broken, loose, cracked or not properly secured.

**Hair Entanglement:** When the hair tangles or knots in the drain cover, trapping the swimmer underwater. This hazard is present when the flow rating of the cover is too small for the pump or pumps.

**Body Entrapment:** When a portion of the body is held against the drain cover trapping the swimmer underwater. This hazard is present when the drain cover is missing, broken or the cover flow rating is not high enough for the pump or pumps.

**Evisceration/Disembowelment:** When a person sits on an open pool (particularly a child wading pool) or spa outlet and suction is applied directly to the intestines, causing severe intestinal damage. This hazard is present when the drain cover is missing, loose, cracked, or not properly secured.

**Mechanical Entrapment:** When jewelry, swimsuit, hair decorations, finger, toe or knuckle is caught in an opening of an outlet or drain cover. This hazard is present when the drain cover is missing, broken, loose, cracked, or not properly secured.

**NOTE: ALL SUCTION PLUMBING MUST BE INSTALLED IN ACCORDANCE WITH THE LATEST NATIONAL AND LOCAL CODES, STANDARDS AND GUIDELINES.**



## IMPORTANT SAFETY INSTRUCTIONS

### **WARNING** TO MINIMIZE THE RISK OF INJURY DUE TO SUCTION ENTRAPMENT HAZARD:

- A properly installed and secured ANSI/ASME A112.19.8 approved anti-entrapment suction cover must be used for each drain.
- Each suction cover must be installed at least three (3') feet apart, as measured from the nearest point to nearest point.
- Regularly inspect all covers for cracks, damage and advanced weathering.
- If a cover becomes loose, cracked, damaged, broken or is missing, replace with an appropriate certified cover.
- Replace drain covers as necessary. Drain covers deteriorate over time due to exposure to sunlight and weather.
- Avoid getting hair, limbs or body in close proximity to any suction cover, pool drain or outlet.
- Disable suction outlets or reconfigure into return inlets.

**WARNING** The pump can produce high levels of suction within the suction side of the plumbing system. These high levels of suction can pose a risk if a person comes within the close proximity of the suction openings. A person can be seriously injured by this high level of vacuum or may become trapped and drown. It is absolutely critical that the suction plumbing be installed in accordance with the latest national and local codes for swimming pools.

**WARNING** A clearly labeled emergency shut-off switch for the pump must be in an easily accessible, obvious place. Make sure users know where it is and how to use it in case of emergency.

### **CAUTION** For Installation of Electrical Controls at Equipment Pad (ON/OFF Switches, Timers and Automation Load Center)



Install all electrical controls at equipment pad, such as on/off switches, timers, and control systems, etc. to allow the operation (startup, shut-down, or servicing) of any pump or filter so the user does not place any portion of his/her body over or near the

pump strainer lid, filter lid or valve closures. This installation should allow the user enough space to stand clear of the filter and pump during system start-up, shut down or servicing of the system filter.

**WARNING** Pumps improperly sized or installed or used in applications other than for which the pump was intended can result in severe personal injury or death. These risks may or severe injury or property damage caused by a structural failure of the pump or other system component.

### **DANGER** HAZARDOUS PRESSURE: STAND CLEAR OF PUMP AND FILTER DURING START UP.



Circulation systems operate under high pressure. When any part of the circulating system (i.e. locking ring, pump, filter, valves, etc.) is serviced, air can enter the system and become pressurized. Pressurized air can cause the pump housing cover, filter lid, and valves to violently

separate which can result in severe personal injury or death. Filter tank lid and strainer cover must be properly secured to prevent violent separation. Stand clear of all circulation system equipment when turning on or starting up pump. Before servicing equipment, make note of the filter pressure. Be sure that all controls are set to ensure the system cannot inadvertently start during service. Turn off all power to the pump. **IMPORTANT: Place filter manual air relief valve in the open position and wait for all pressure in the system to be relieved.**

Before starting the system, fully open the manual air relief valve and place all system valves in the "open" position to allow water to flow freely from the tank and back to the tank. Stand clear of all equipment and start the pump.

**IMPORTANT: Do not close filter manual air relief valve until all pressure has been discharged from the valve and a steady stream of water appears.** Observe filter pressure gauge and be sure it is not higher than the pre-service condition.

#### General Installation Information

- All work must be performed by a qualified service professional, and must conform to all national, state, and local codes.
- Install to provide drainage of compartment for electrical components.
- These instructions contain information for a variety of pump models and therefore some instructions may not apply to a specific model. All models are intended for use in swimming pool applications. The pump will function correctly only if it is properly sized to the specific application and properly installed.

# TABLE OF CONTENTS

---

|  |            |                                   |           |
|--|------------|-----------------------------------|-----------|
| <b>Important Safety Instructions</b> ..... | <b>i</b>   |                                   |           |
| <b>Introduction</b> .....                  | <b>1</b>   | <b>Maintenance</b> .....          | <b>11</b> |
| Pump Features                              | 1          | Cleaning the Pump Strainer Basket | 11        |
| Motor Features                             | 1          | Motor Care                        | 11        |
| Drive Features                             | 1          | Pump Disassembly                  | 12        |
| <b>Using the Drive Keypad</b> .....        | <b>2/3</b> | Pump Reassembly                   | 12        |
| <b>Installation</b> .....                  | <b>4</b>   | Restarting the Pump               | 13        |
| Location                                   | 4          | Winterizing                       | 13        |
| Piping                                     | 4          | <b>Troubleshooting</b> .....      | <b>14</b> |
| Fitting and Valves                         | 4          | Troubleshooting Chart             | 14        |
| Electrical Installation                    | 5          | Alarms and Fault Codes            | 15        |
| Wiring                                     | 5          | <b>Replacement Parts</b> .....    | <b>16</b> |
| Grounding                                  | 5          | <b>Technical Data</b> .....       | <b>17</b> |
| Bonding                                    | 5          | Technical Specifications          | 17/18     |
| <b>Operation</b> .....                     | <b>6</b>   | Performance Curves                | 17/18     |
| Setting the Clock and Pump Address         | 6          | Pump Dimensions                   | 19        |
| Using the Default Schedule                 | 6          |                                   |           |
| Programming a Custom Schedule              | 7          |                                   |           |
| Speed Priorities (Non-External Control)    | 8          |                                   |           |
| Operating the Pump While Running           | 8          |                                   |           |
| Priming                                    | 9          |                                   |           |
| Programming Quick Clean                    | 10         |                                   |           |
| Factory Reset                              | 10         |                                   |           |



# INTRODUCTION

## Pump Features

- Extremely quiet operation
- 2 in. Plumbing for simple replacement
- See-through strainer pot lid allows easy inspection of strainer basket
- Self-priming for quick, easy start-up

## Motor Features

- High-Efficiency Permanent Magnet Motor
- 56 Square Flange
- Low noise
- Designed to withstand outdoor environment
- Operates at lower temperatures due to high efficiency
- Exceeds all Department of Energy and Energy Star requirements.
- Permanent-magnet, totally enclosed fan-cooled (TEFC) motor.
- WEF:0.7 THP:10.66 (1.5 HP models)
- WEF:1.10 THP:8.243 (2 HP models)
- WEF:1.72 THP:7.385 (3 HP models)

## Drive Features

The pump features a premium efficiency variable frequency drive that provides flexibility in terms of motor speed and duration settings.

### **WARNING**

This pump is for use with 230 Vrms nominal, and in pool pump applications ONLY. Connection to the wrong voltage, or use in other applications may cause damage to equipment or personal injury.

The pump's drive controls the speed settings as well as run durations. The pump can operate at speeds ranging between 1000 and 3450 RPM and will operate within the voltage of 230 Vrms nominal at either 50 or 60Hz input frequency.

The pump is intended to run at the lowest speeds needed to maintain a sanitary environment and, at the same time, minimize energy consumption. Factors such as pool size, the presence of additional water features, type of chemicals used to maintain sanitary conditions, and local environmental factors will impact optimal programming to maximize energy conservation. Determining the optimal settings and programming for your pool may require some trial-and-error.

- Simple user interface
- UV and rain-proof enclosure
- Onboard time of day schedule
- Adjustable priming mode
- Programmable Quick Clean mode
- Pump alarm display and retention
- Accepts 230V, 50/60Hz input power
- Auto power limiting protection circuit
- 24hr. clock retention for power outages

| Model  | Voltage (VAC) | Max Amps | Input (Hz) |
|--------|---------------|----------|------------|
| 1.5 HP | 230           | 5        | 50/60      |
| 2 HP   | 230           | 7.5      | 50/60      |
| 3 HP   | 230           | 11       | 50/60      |



# USING THE DRIVE KEYPAD

Before operating the pump for the first time, the pump's internal clock and operational schedules must be programmed. Refer to *Setting the Clock and Pump Address, page 6* and *Programming Custom Schedules, page 7* for instructions regarding the programming of this pump for scheduled operation.

The pump can be programmed and controlled from the drive keypad. Pump features and settings are also accessed using this keypad.

**Note: Functionality may vary based on other active features such External Control Only Mode and/or Keypad Lockout.**

**Note:** Always close the keypad cover after use. This will prevent damage to the keypad and other drive components.

**CAUTION:** Only press keypad buttons with your fingers. Using screwdrivers, pens or other tools to program the pump will damage the keypad.

**WARNING:** If power is connected to the pump motor, pressing any of the following buttons referred to in this section could result in the motor starting. Failure to recognize this could result in personal injury or damage to equipment.

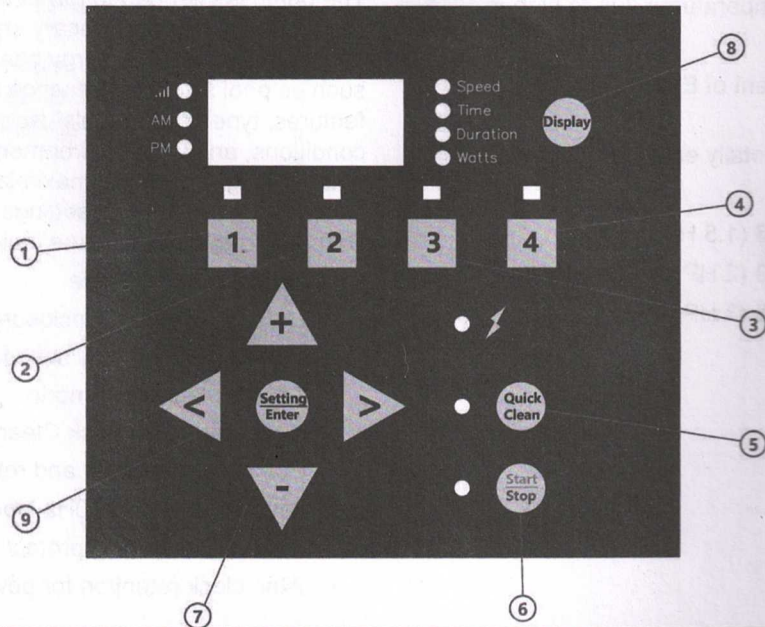

- ① SPEED 1: Press to select Speed 1(2850 RPM), and the LED light indicates that the current speed 1 is running
- ② SPEED 2: Press and select Speed 2(1730 RPM). When the LED is on, it indicates that the current speed 2 is running
- ③ SPEED 3: Press and select speed 3(2300 RPM), and the LED light indicates that the current speed 3 is running
- ④ SPEED 4: Press and select Speed 4(1150 RPM). When the LED is on, the speed 4 is running
- ⑤ Quick Clean key: Quick clean key
- ⑥ Start/Stop key: Start/stop key: Start or stop the pump. When the indicator light is on, it indicates that the pump is running or in the specified mode. When the light blinks, it means that the pump is not running and the current time has not reached the start time of the next scheduled mode.
- ⑦ When the frequency converter is shut down, enter the main menu directory
- ⑧ Display button: used to switch between display contents when the water pump is running.
- ⑨ Arrow keys

- on key: Increase the speed or time when adjusting
- under key: reduce the speed or time when adjusting
- left key: Move cursor to left



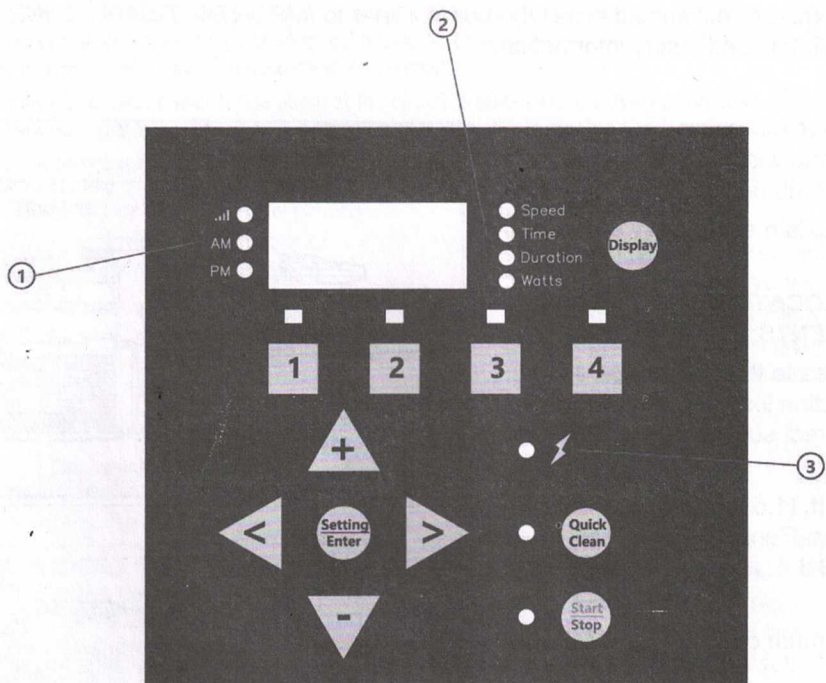

- ① Control panel digital tube: used to view the current speed, time, duration, power consumption, Bluetooth connection prompt and other functions.
- ② Display mode LED indicator light: with the display button to display the corresponding LED, the information displayed on the digital tube corresponds to a specific point. Blinking indicates the current editable parameter.
- ③ Power LED indicator: When the LED light shines, it means that the pump has been energized.



# INSTALLATION

Only a qualified plumbing professional should install the pump. Refer to *IMPORTANT SAFETY INSTRUCTIONS* on page i-ii for additional installation and safety information.

## Location

**Note:** Do not install this pump within an outer enclosure or beneath the skirt of a hot tub or spa.

**Note:** Ensure that the pump is mechanically secured to the equipment pad.

### ENSURE THE INSTALL LOCATION MEETS THE FOLLOWING REQUIREMENTS:

1. Install the pump as close to the pool or spa as possible. To reduce friction loss and improve efficiency, use short, direct suction and return piping.
2. Install a minimum of 5 ft. (1.5 m) from the inside wall of the pool and spa. Canadian installations require a minimum of 9.8 ft. (3 m) from the inside wall of the pool.
3. Install the pump a minimum of 3 ft. (0.9 m) from the heater outlet.
4. Do not install the pump more than 5 ft. (1.5 m) above the water level.
5. Install the pump in a well ventilated location protected from excess moisture (i.e. rain gutter downspouts, sprinklers, etc.).
6. Install the pump with a rear clearance of at least 3 in. (7.6 cm) so that the motor can be removed easily for maintenance and repair. See **Figure 1**.

## Piping

1. For improved pool plumbing, it is recommended to use a larger pipe size.
2. Piping on the suction side of the pump should be the same or larger than the return line diameter.
3. Plumbing on the suction side of the pump should be as short as possible.
4. For most installations recommends installing a valve on both the pump suction and return lines so that the pump can be isolated during routine maintenance. However, we also recommend that a valve, elbow or tee installed in the suction line should be no closer to the front of the pump than five (5) times the suction line diameter. See **Figure 2**.

**Example:** A 2.5 in. pipe requires a 12.5 in. (31.8 cm) straight run in front of the suction port. This will help the pump prime faster and last longer.

**Note:** DO NOT install 90° elbows directly into the suction or discharge ports.

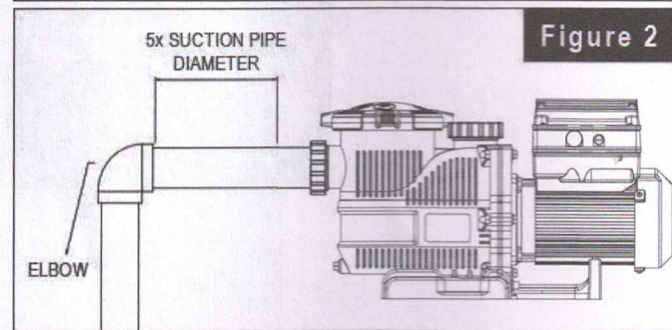
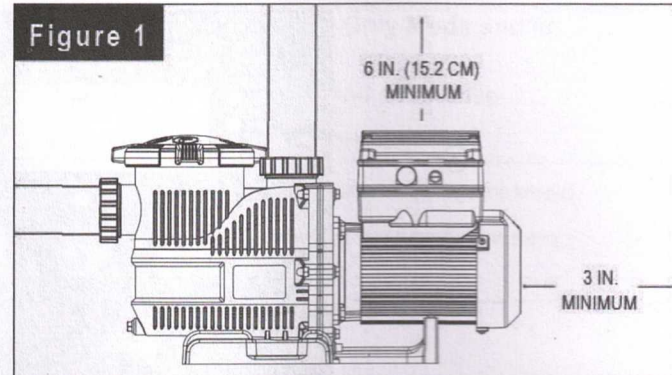

## Fittings and Valves

1. Do not install 90° elbows directly into suction port.
2. Flooded suction systems should have gate valves installed on suction and discharge pipes for maintenance, however, the suction gate valve should be no closer than five times the suction pipe diameter as described in this section.
3. Use a check valve in the discharge line when using this pump for any application where there is significant height to the plumbing after the pump.
4. Be sure to install check valves when plumbing in parallel with another pump. This helps prevent reverse rotation of the impeller and motor.



## Electrical Installation

### **WARNING**



**RISK OF ELECTRICAL SHOCK OR ELECTROCUTION.** The pump must be installed by a licensed or certified electrician or a qualified service professional in accordance with the National Electrical Code and all applicable local codes and ordinances. Improper installation will create an electrical hazard which could result in death or serious injury to users, installers, or others due to electrical shock, and may also cause damage to property.

**Always disconnect power to the pump at the circuit breaker before servicing the pump. Failure to do so could result in death or serious injury to service people, pool users or others due to electric shock and/or property damage.**

Read all servicing instructions before working on the pump.

The pump accepts 230 V, 50 or 60 Hz single phase input power. Power Connections are capable of handling up to 8 AWG solid or stranded wire.

### Wiring

1. Ensure all electrical breakers and switches are turned off before wiring the motor.

### **WARNING**

**STORED CHARGE** - Wait at least 5 minutes before servicing.

2. Ensure supply voltage meets the requirements listed on the motor nameplate.
3. For wiring sizes and general requirements, follow specifications defined by the current National Electric Code and any local codes. When in doubt use a heavier gauge (larger diameter) wire.
4. Ensure all electrical connections are clean and tight.
5. Cut all wiring to the appropriate length so they do not overlap or touch when connected to terminals.
6. ALWAYS reinstall the drive lid after electrical installation or before leaving the pump unsupervised during servicing. This will prevent rainwater, dust or other foreign matter from accumulating in the drive.

**Note:** Ensure wires are not pinched between the drive body and lid.

### Grounding

1. Permanently ground the motor using the Grounding Terminal inside the drive wiring compartment. Refer to the current National Electrical Code and any local codes for wire size and type requirements. Ensure the ground wire is connected to an electrical service ground.

### Bonding

1. Using the Bonding Lug located on the side of the motor, bond the motor to all metal parts of the pool structure, electrical equipment, metal conduit and metal piping within 5 ft.(1.5m) of the inside walls of the swimming pool, spa or hot tub in accordance with the current National Electrical Code and any local codes.
2. Solid copper bonding conductor of 8 AWG or larger is required. For Canadian installations, 6 AWG or larger solid copper bonding conductor is required.

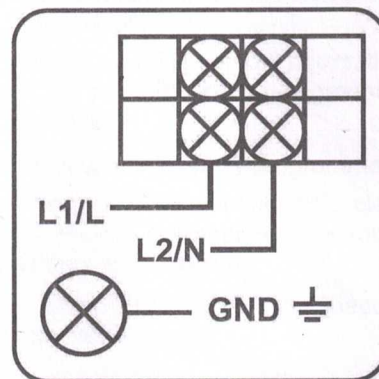



# OPERATION

Before operating the pump for the first time, the pump's internal clock and operational schedules must be programmed by following the steps in this manual. Refer to *Setting the Clock and Pump Address* below and *Programming Custom Schedules on page 7*, for instructions regarding the programming of this pump for scheduled operation.

## Setting the Clock and Pump Address

When power is first connected to the pump the clock will blink to indicate that it has not been set. Custom schedules are based on this clock setting, so the clock must be set first.

1. Press **Setting**.
2. Use "+" and "-" to program the current time.  
Use "<" and ">" to moving the modify cursor.  
**Note:** In the 12 hours time format AM/PM will display on the left.
3. Turn on the Bluetooth function of your phone.  
After connecting to the water pump with our application, the app connection prompt light at the upper left corner of the operation interface will light up, and the time on the water pump will be automatically calibrated and saved.

## Using the Default Schedule

The default schedule is designed to provide sufficient daily turnover for a typical pool. See **Table 2** for default schedule.

| The program                         | Start up time                  | Time of operation | Default speed            |
|-------------------------------------|--------------------------------|-------------------|--------------------------|
| The default cycle is 22 hours a day |                                |                   |                          |
| speed1                              | 8:00AM(8:00)<br>(adjustable)   | 2H(adjustable)    | 2850 RPM<br>(adjustable) |
| speed2                              | 10:00AM(10:00)<br>(adjustable) | 10H(adjustable)   | 1730 RPM<br>(adjustable) |
| speed3                              | 8:00PM(20:00)<br>(adjustable)  | 2H(adjustable)    | 2300 RPM<br>(adjustable) |
| speed4                              | 10:00PM(22:00)<br>(adjustable) | 8H(adjustable)    | 1150 RPM<br>(adjustable) |

**Table 3**

**The default schedule will operate as follows:**

1. SPEED 1 will begin at 8:00am and run at 2850 RPM for a duration of 2 hours.
2. SPEED 2 will begin at 10:00am and run at 1730 RPM for a duration of 10 hours.
3. SPEED 3 will begin at 8:00pm and run at 2300 RPM for a duration of 2 hours.
4. SPEED 4 will begin at 10:00pm and run at 1150 RPM for a duration of 8 hours.
5. At the end of speed 4, the pump will stop running for 2 hours and then run speed 1 again. Because the factory is set to run continuously for 22 hours every day until the user changes the default schedule.

**Note:** The **Start/Stop** button must be pressed, and the Start/Stop LED illuminated, for the pump to run.



## Programming Custom Schedules

To customize your pump's schedule, the pump must be stopped. Ensure that the Start/Stop LED is not illuminated.

When programming, the LED next to the parameter you are editing will blink.

“Speed” - Run Speed

“Time” - Start Time

“Duration” - Run Time

### TO PROGRAM A CUSTOM SCHEDULE:

1. Press **Start/Stop** to stop the pump.
2. Press “1”. The SPEED 1 LED and the “Speed” parameter LED will blink while editing. See **Figure 9**.



Figure 9

3. Use “+” and “-” to adjust the speed in RPM for SPEED 1, use the “<” and “>” move the cursor.

**Note:** The speed adjustment Stepping is 100/10/1rpm

4. Press “1”. The SPEED 1 start time will display. The “Time” parameter LED will begin to blink. See **Figure 10**.

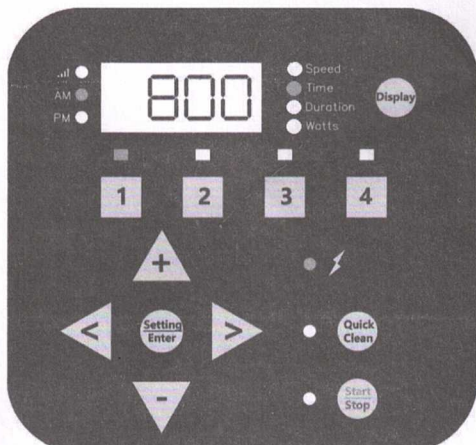

Figure 10

5. Use “+” and “-” to adjust the SPEED 1 start time. use the “<” and “>” move the cursor.

**Note:** The start time adjustment Stepping is 1hour/10min/1min

6. Press “1”. SPEED 1 duration will display. The “Duration” parameter LED will begin to blink. See **Figure 11**.

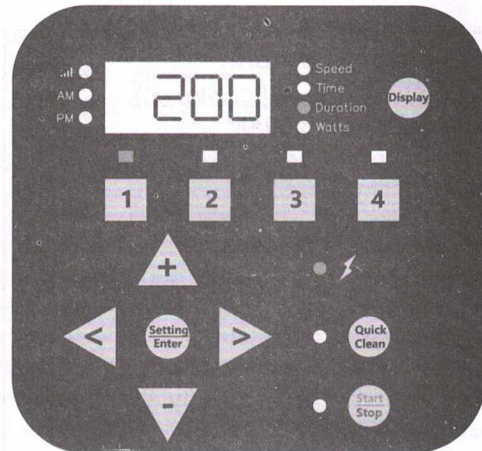

Figure 11

7. Use “+” and “-” to adjust the SPEED 1 duration in hours and minutes, use the “<” and “>” move the cursor.

**Note:** The duration adjustment Stepping is 1hour/10min

**Note:** If the duration is set to 0 hours, the pump will not run this program segment during this period

8. SPEED 1 is now successfully programmed.

**Note:** Pressing “1” will continue to cycle through these parameters, but changes are immediately saved as they are adjusted.

9. Press “2”. The SPEED 2 LED and “Speed” parameter LED will blink while editing.

10. Use “+” “-” “<” and “>” to adjust the speed in RPM for SPEED 2.

11. Press “2”. The SPEED 2 duration will display.

12. Use “+” “-” “<” and “>” to adjust the duration of SPEED 2 in hours and minutes.

13. Repeat steps 9-12 to program SPEED 3, 4 and QUICK CLEAN.

14. Press **Start/Stop** and ensure the Start/Stop LED is illuminated. The pump is now active and will run the programmed schedule.

**Note:** If the pump was stopped using the **Start/Stop** button, the pump will not run until the **Start/Stop** button is pressed again. If the Start/Stop LED is illuminated, the pump is on and will run the programmed schedule.



## Speed Priorities (Non-External Control)

For schedule duration settings, SPEEDs are prioritized as follows: SPEED 1 -> SPEED 2 -> SPEED 3 -> SPEED 4. SPEED 1 is the highest priority, while SPEED 4 is the lowest.

The drive has priority Settings, as shown in the following table.

### **Example:**

#### Starting Schedule (Before Adjustment)

SPEED 1 start time = 8:00AM  
duration = 6 hours  
SPEED 2 start time = 9:00AM  
duration = 1 hours  
SPEED 3 start time = 10:00AM  
duration = 1 hours  
SPEED 4 start time = 2:00PM  
duration = 1 hours

In this way, according to the priority, the water pump will run the speed1 mode from 8:00 a.m. to 2:00 p.m. (skip the speed2 and 3 modes in the middle, because speed2 and 3 have been included in the speed1 operation period), and the speed4 mode will run from 2:00 p.m. to 3:00 p.m.

#### End Schedule (After Adjustment)

SPEED 1 start time = 8:00AM  
duration = 6 hours  
SPEED 4 start time = 2:00PM  
duration = 1 hours

## Operating the Pump While Running



If power is connected to the pump, pressing any of the following buttons referred to in this section could result

in the motor starting. Failure to recognize this could result in personal injury or damage to equipment.

Pressing the **Display** button will cycle through the current parameters:

**Speed** — current run speed

**Time** — current time of day

**Duration** — amount of time remaining at current run speed

**Watts** — watts currently being consumed

Pressing any of the SPEED Buttons (“1”, “2”, “3”, “4” or **Quick Clean**) while the pump is running will act as a temporary override. The pump will run the speed and duration programmed for that button. Once completed the pump will return to the appropriate point in the programmed schedule.

**Note:** If schedule speeds are adjusted while the pump is running, the pump will run the entered speed for the rest of the program's duration, but will not save the adjustments.

## Priming

### ⚠ CAUTION

This pump is shipped with Priming mode ENABLED. The pump will ramp up to 3450 RPM when the pump is initially started.

#### Before turning the pump ON:

1. Open filter air relief valve.
2. Open necessary valves.
3. Ensure return line is completely open and clear of any blockages.
4. Ensure pump is filled with water.
5. Stand clear of the filter or other pressurized vessels.

DO NOT run the pump dry, the shaft seal will be damaged and the pump will start leaking. If this occurs, the damaged seal must be replaced. ALWAYS maintain proper water level in your pool (half way up skimmer opening). If the water level

falls below the skimmer opening, the pump will draw air through the skimmer, losing the prime and causing the pump to run dry, resulting in a damaged seal. Continued operation in this manner could cause a loss of pressure, resulting in damage to the pump body, impeller and seal and may cause property and personal injury.

When the pump starts, the start will run automatically in addition to running a quick cleaning cycle. The default startup speed is 3200 RPM and will last 5 minutes. The drive will display the remaining time

**Note:** After the pump's priming cycle has completed, if there is time remaining on the control system's priming timer the pump will run the control system priming speed until the timer expires.

During boot, the boot speed can be adjusted between 1700 RPM and 3200 RPM with "+" and "-".

The first startup starts with a countdown of 5 minutes.

Priming time can change based on local environmental conditions such as water temperature, atmospheric pressure, and your pool's water level. All of these things should be taken into consideration when setting the priming speed. Test and verify priming speeds more than once, letting the water drain from the system in between each test.

**Note:** To prevent air from entering the system, the pump strainer pot should always be filled with water up to the bottom of the suction port.



## Programming Quick Clean

The pump is equipped with a Quick Clean feature, which can be engaged to temporarily run at higher or lower speeds ranging from 1700 to 3450 RPM.

At the end of a Quick Clean cycle, the pump will automatically return to the appropriate point in its programmed schedule.

### TO PROGRAM QUICK CLEAN:

1. Press **Start/Stop** to stop the pump.
2. Press **Quick Clean**. The Quick Clean LED and "Speed" parameter LED will blink while editing. See **Figure 14**.



Figure 14

3. Use "+" and "-" to adjust the Quick Clean speed in RPM, use the "<" and ">" move the cursor.

**Note:** The speed adjustment Stepping is 100/10/1rpm

4. Press **Quick Clean**. The Quick Clean duration will display. The "Duration" parameter LED will blink while editing. See **Figure 15**.

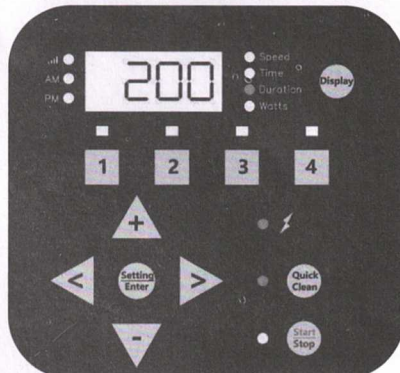

Figure 15

6. Use "+" and "-" to adjust the Quick Clean duration in hours and minutes, use the "<" and ">" move the cursor.

**Note:** Quick Clean duration does not affect the start

## Factory Reset

The drive can be reset to factory settings if necessary. A Factory Reset will erase all programmed settings and schedules, except for the time of day. Be sure that it is necessary before performing a Factory Reset, as the results are immediate.

### TO PERFORM A FACTORY RESET:

1. If the pump is running, press the **Start/Stop** button to stop the pump.
2. Press and hold "1", "2" for 3 seconds.
3. If factory reset is successfully, you will hear 3-second prompt tone.
4. Reprogram the schedule and priming speed described in the previous sections. The pump must be turned back on with the Start/Stop button before it will run again. The pump will then follow the programmed schedule upon initial start-up.



# MAINTENANCE



**WARNING** **DO NOT** open the strainer pot if pump fails to prime or if pump has been operating without water in the strainer pot. Pumps operated in these circumstances may experience a build up of vapor pressure and may contain scalding hot water. Opening the pump may cause serious personal injury. In order to avoid the possibility of personal injury, make sure the suction and discharge valves are open and strainer pot temperature is cool to touch, then open with extreme caution.



Always disconnect power to the pump at the circuit breaker and disconnect the digital input cable before servicing the pump. Failure to do so could result in death or serious injury to service people, users or others due to electric shock. Read all servicing instructions before working on the pump.



To prevent damage to the pump and for proper operation of the system, clean pump strainer and skimmer baskets regularly.

## Cleaning the Pump Strainer Basket

The strainer pot is located at the front of the pump and houses the pump strainer basket.

The strainer basket can be viewed through the strainer pot lid and should be visually inspected at least once a week. Regularly emptying and cleaning the strainer basket will lead to higher filter and heater efficiency and prevent unnecessary stress on the pump motor.

### TO CLEAN THE STRAINER BASKET:

1. Press **Start/Stop** to stop the pump and shut off all electrical power to the pump at the circuit breaker.
2. Open the filter air relief valve and relieve all pressure from the filtration system.
3. Turn the strainer pot lid counter-clockwise and remove it from the pump.
4. Remove debris and rinse out the basket. Replace the basket if it is cracked or damaged.
5. Place the basket into the strainer pot. Ensure the notch in the bottom of the basket is aligned with the rib in the bottom of the strainer pot.
6. Fill the strainer pot with water up to the inlet port.
7. Clean the lid O-ring and sealing surface of the strainer pot.  
**Note:** It is important to keep the lid O-ring clean and well lubricated.
8. Reinstall the lid by placing it onto the strainer pot and tightening clockwise until the lid handles are horizontal.  
**Note:** Ensure the lid O-ring is properly placed and is not being pinched between the lid and strainer pot.  
**Note:** Ensure that the side of the lid marked "Front" is positioned at the front of the pump.
9. Open the filter air relief valve and stand clear of the filter.
10. Reestablish electrical power to the pump at the circuit breaker and start the pump.
11. When a steady stream of water flows from the filter air relief valve, close the valve

## Motor Care

### Protect from heat

1. Shade the motor from the sun.
2. Any enclosure must be well ventilated to prevent overheating.
3. Provide ample cross ventilation.

### Protect against dirt

1. Protect from any foreign matter.
2. Do not store (or spill) chemicals on or near the motor.
3. Avoid sweeping or stirring up dust near the motor while it is operating.
4. If the motor has been damaged by dirt it may void the motor warranty.
5. Clean the lid, O-ring, and sealing surface of the strainer pot regularly.

### Protect against moisture

1. Protect from splashing or sprayed water.
2. Protect from extreme weather.
3. If motor internals have become wet - let them dry before operating. Do not allow the pump to operate if it has been flooded.
4. If the motor has been damaged by water it may void the motor warranty.



**THIS SYSTEM OPERATES UNDER HIGH PRESSURE.** When any part of the circulating system is serviced, air can enter the system and become pressurized. Pressurized air can cause the lid to separate which can result in serious injury, death, or property damage. To avoid this potential hazard, follow above instructions.





Refer to the *Motor/Hydraulics Assembly Diagram*, on the next page, for a parts breakdown of the pump.



**WARNING** Always disconnect power to the pump at the circuit breaker before servicing the pump. Failure to do so could result in death or serious injury to service people, users or others due to electric shock. Read all servicing instructions before servicing the pump.



**WARNING** **DO NOT** open the strainer pot if pump fails to prime or if pump has been operating without water in the strainer pot. Pumps operated in these circumstances may experience a build up of vapor pressure and may contain scalding hot water. Opening the pump may cause serious personal injury. In order to avoid the possibility of personal injury, make sure the suction and discharge valves are open and strainer pot temperature is cool to touch, then open with extreme caution.

## Pump Disassembly

### TOOLS REQUIRED:

- Adjustable wrench
- #2 Phillips screwdriver
- Flat blade screwdriver

### TO DISASSEMBLE THE PUMP:

1. Press **Start/Stop** to stop the pump and disconnect all power to the pump at the circuit breaker.
2. Disconnect any digital inputs or communication cables from the pump (if connected).
3. Close all valves in suction and discharge lines.
4. Relieve all system pressure at the filter's air relief valve.
5. Remove both drain plugs from the bottom of the strainer pot.
6. Using an adjustable wrench, remove the two strainer pot through-bolts and nuts securing the motor/hydraulics assembly to the strainer pot.
7. Using an adjustable wrench, open-end wrench or socket, remove the four remaining strainer pot bolts.
8. GENTLY separate the motor/hydraulics assembly from the strainer pot.
9. Using an adjustable wrench, remove the two screws securing the diffuser to the seal plate. Remove the diffuser.
10. Using an adjustable wrench, hold the motor shaft in place at the rear of the motor. This will prevent the motor shaft from spinning while removing the impeller and impeller screw.
11. Continue to hold the motor shaft in place. Remove the impeller screw and washer clockwise using a #2 Phillips screwdriver.
12. Remove the impeller counter-clockwise by hand.
13. Using a 9/16 in. wrench, remove the four (4) bolts securing the seal plate to the motor.
14. Remove the seal plate from the motor/drive assembly.

## Pump Reassembly

1. Place the seal plate onto the motor assembly, ensuring the side marked "UP" is at the top.
2. Using an adjustable wrench, reinstall the motor/sealplate Bolts in a criss-cross pattern the seal plate to the motor with the four motor bolts. Tighten to 70-80 in-lbs. (81-92 kg/cm).
3. Using an adjustable wrench, hold the motor shaft in place at the rear of the motor. This will prevent the motor shaft from spinning while reinstalling the impeller and impeller screw.
4. Continue to hold the motor shaft in place and reinstall the impeller onto the motor shaft clockwise hand tight.
5. Continue to hold the motor shaft in place and reinstall the impeller screw and washer. Tighten to 25 in-lbs. (29 kg/cm).  
**Note:** The impeller screw is reverse threaded and tightens counter-clockwise.
6. Reinstall the diffuser onto the seal plate using the two diffuser screws.
7. Inspect the diffuser seal and seal plate gasket for damage and replace if necessary. Grease both before continuing.
8. Using an adjustable wrench, secure the strainer pot to the motor/hydraulics assembly with the six strainer pot bolts and washers.  
**Note:** Do not tighten the two through-bolts until six bolts are in place and finger tightened. Tighten in a criss-cross pattern to 110 in-lbs (127 kg/cm).  
**Note:** Ensure the seal plate gasket is not pinched between the strainer pot and motor assembly.
9. Reinstall the both drain plugs into the bottom of the strainer pot.
10. To restart the pump, continue to *Restarting the Pump*, page 13.



## Restarting the Pump

If pump is installed below the water level of the pool, close return and suction lines prior to opening the strainer pot on pump. Make sure to re-open valves prior to operating.



**DO NOT run the pump dry.** The shaft seal will be damaged and require replacement.

ALWAYS maintain proper water level in your pool (half way up the skimmer opening). If the water level falls below the skimmer opening, the pump will draw air through the skimmer, lose prime and cause the pump to run dry. Continued operation in this manner could cause a loss of pressure, damage the pump and/or property or personal injury.

### TO PRIME THE PUMP:

1. Press **Start/Stop** to stop the pump and disconnect all power to the pump at the circuit breaker.
2. Relieve all pressure from the filtration system at the filter air relief valve.
3. Remove the strainer pot lid by twisting it in a counter-clockwise direction.
4. Fill the strainer pot up to the inlet port with water.
5. Place the lid onto the strainer pot, then turn clockwise to lock in place.  
**Note:** The lid is properly locked when the handles are nearly perpendicular to the pump body.
6. Return power to the pump at the circuit breaker.
7. Open the filter air relief valve.
8. Stand clear of the filter and press the **Start/Stop** button to start the pump.
9. Bleed air from the filter air relief valve until a steady stream of water appears, then close the relief valve.
10. The pump will run a priming cycle and, if successful, begin normal operation.

## Winterizing

You are responsible for determining when freezing conditions may occur. If freezing conditions are expected, take the following steps to reduce the risk of freeze damage. **Freeze damage is not covered under warranty.**

In mild climate areas, when temporary freezing conditions may occur, run your filtering equipment all night to prevent freezing.

### TO PREVENT FREEZE DAMAGE:

1. Press **Start/Stop** to stop the pump and disconnect all power to the pump at the circuit breaker.
2. Disconnect all power to the pump at the circuit breaker.
3. Relieve all pressure from the filtration system at the filter air relief valve.
4. Remove both drain plugs from the bottom of the strainer pot and drain the pump. Store the plugs in the strainer basket.
5. Cover the motor to protect it from severe rain, snow and ice.

**Note:** Do not wrap motor with plastic or other air tight materials during winter storage. Never cover the motor when operating or expecting operation.



# TROUBLESHOOTING



**WARNING** Diagnosing certain symptoms may require interaction with, or close proximity to, components that are energized with electricity. All servicing should be performed by a qualified service professional. Contact with electricity can cause death, personal injury, or property damage.

## Troubleshooting Chart

| Problem                              | Possible Cause                                    | Corrective Action  |
|--------------------------------------|---|--|
| <b>Pump failure.</b>                 | Pump will not prime - Air in suction line or pump | <ol style="list-style-type: none"> <li>1. Inspect suction line plumbing and valve(s) for damage or loose connections.</li> <li>2. Ensure the strainer pot lid is sealing properly. Verify lid O-ring is in place.</li> <li>3. Ensure proper pool water level and water is available to the skimmer.</li> </ol> |
|                                      | Pump will not prime - Not enough water            | <ol style="list-style-type: none"> <li>1. Ensure suction line and pump strainer pot are full of water.</li> <li>2. Ensure suction line valve is working and open (some systems do not have valves).</li> <li>3. Ensure proper pool water level and water is available to the skimmer.</li> </ol>               |
|                                      | Strainer basket excessively dirty or full         | Clean strainer basket. See <i>Cleaning the Pump Strainer Basket</i> , page 11.   |
|                                      | Strainer pot O-ring is damaged                    | Inspect strainer pot O-ring for damage. Replace if necessary.  |
| <b>Reduced capacity and/or head.</b> | Air in suction line or pump                       | <ol style="list-style-type: none"> <li>1. Inspect suction line plumbing and valve(s) for damage or loose connections.</li> <li>2. Ensure the strainer pot lid is sealing properly. Verify lid O-ring is in place.</li> <li>3. Ensure proper pool water level and water is available to the skimmer.</li> </ol> |
|                                      | Clogged impeller                                  | Disassemble pump ( <i>Pump Disassembly</i> , page 12) and remove debris from impeller.   |
|                                      | Strainer basket excessively dirty or full         | Clean strainer basket. See <i>Cleaning the Pump Strainer Basket</i> , page 11.   |
| <b>Pump fails to start.</b>          | Mains voltage is not present                      | <ol style="list-style-type: none"> <li>1. Replace fuse, reset breaker</li> <li>2. Tighten mains wire connections.</li> </ol>   |
|                                      | Motor is locked                                   | Disassemble pump ( <i>Pump Disassembly</i> , page 12) and attempt to rotate motor shaft by hand to remove any blockage.  |
|                                      | Motor shaft is damaged                            | Replace pump.  |
| <b>Pump runs then stops.</b>         | Over temperature FAULT                            | Ensure motor fan cover at the rear of the motor is free of dirt and debris. Use compressed air to clean.   |
|                                      | Over current FAULT                                | Pump will automatically restart after one (1) minute.  |
| <b>Pump is noisy.</b>                | Debris in contact with fan                        | Ensure motor fan cover at the rear of the motor is free of dirt and debris. Use compressed air to clean.   |
|                                      | Strainer basket excessively dirty or full         | Clean strainer basket. See <i>Cleaning the Pump Strainer Basket</i> , page 11.   |
|                                      | Loose mounting                                    | Ensure mounting bolts and pump bolts are tight.  |



## Troubleshooting Chart (cont.)

| Problem                 | Possible Cause                 | Corrective Action  |
|-------------------------|--------------------------------|--|
| Pump runs without flow. | Impeller is loose              | Ensure fan at the rear of pump is spinning. If so, disassemble pump ( <i>Pump Disassembly, page 12</i> ) and ensure impeller is correctly installed.<br><br>1. Inspect suction line plumbing and valve(s) for damage or loose connections.<br>2. Ensure the strainer pot lid is sealing properly. Verify lid O-ring is in place.<br>3. Ensure proper pool water level and water is available to the skimmer.<br><br>1. Inspect for and clear any blockage in strainer pot or suction line.<br>2. Inspect for blockage in discharge piping including partially closed valve or dirty pool filter. |
|                         | Air in suction line or pump    |  |
|                         | Clogged or restricted plumbing |  |

## Alarms and Fault Codes

If an alarm is triggered the drive will display a fault code text and the pump will stop running. Disconnect power to the pump and wait until the keypad LEDs have all turned off, then reconnect power. If the error continues to appear after power is reconnected, proper troubleshooting will be required. Use the error description table below to begin troubleshooting.

| Fault Code | Description   |
|------------|---|
| 1          | Blocked or motor wire short circuit or high temperature rise    |
| 2,4,6      | The input voltage is too high                                   |
| 8          | The input voltage is too low                                    |
| 16,128     | Motor fails to start normally                                   |
| 256        | Motor phase loss or the motor and driver are not connected well |
| 300        | No load   |
| 301        | Overtemperature   |

**POWER OUT FAILURE** – Incoming supply voltage is less than 190 VAC or the controller is disturbed, and the input voltage exceeds the limit value.

**16,128 – Motor fails to start normally:** The motor is stuck, or the ground wire of the motor is not properly connected, or the driver is not correctly installed on the motor.

**300 – No load:** Water may not be absorbed.

**301 – Overtemperature:** The temperature of components inside the driver exceeds the limit.

**It is possible to have two or more abnormalities at the same time. For example, when the motor stops abnormally, error code 7 is displayed, indicating the superposition of error codes 1, 2 and 4.**



# 73150/73300

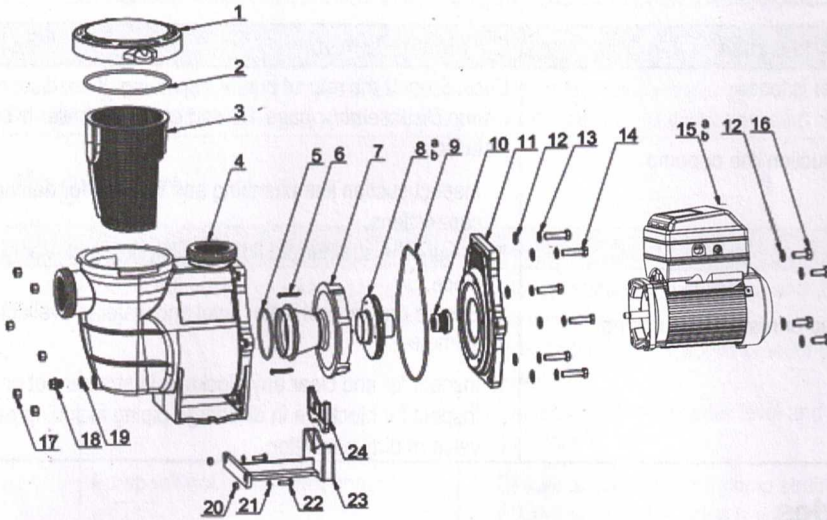

|            |   |               |               |    |
|------------|---|---------------|---------------|----|
| <b>1</b>   | COVER FOR 73150 & 73300                 | 73300COVER    | 73300COVER    | 1  |
| <b>2</b>   | O RING FOR COVER FOR 73150 & 73300      | 73300CORING   | 73300CORING   | 1  |
| <b>3</b>   | STRAINER BASKET FOR 73150 & 73300       | 73300BASKET   | 73300BASKET   | 1  |
| <b>4</b>   | PUMP HOUSING FOR 73150 & 73300          | NA            | NA            | 1  |
| <b>5</b>   | SMALL INTERNAL O RING FOR 73150 & 7330  | 73300SORING   | 73300SORING   | 1  |
| <b>6</b>   | INTERNAL SCREWS                         | NA            | NA            | 2  |
| <b>7</b>   | DIFFUSER FOR 73150 & 73300              | 73300DIFFUSE  | 73300DIFFUSE  | 1  |
| <b>8A</b>  | IMPELLER FOR 73150                      | 73150IMPELLER | NA            | 1  |
| <b>8B</b>  | IMPELLER FOR 73300                      | NA            | 73300IMPELLER | 1  |
| <b>9</b>   | LARGE INTERNAL O RING FOR 73150 & 73300 | 73300LORING   | 73300LORING   | 1  |
| <b>10</b>  | SEAL ASSEMBLY FOR 73150 & 73300         | 73300SEAL     | 73300SEAL     | 1  |
| <b>11</b>  | INTERNAL PUMP COVERS FOR 73150 & 73300  | NA            | NA            | 1  |
| <b>12</b>  | INTERNAL GASKETS FOR 73150 & 73300      | NA            | NA            | 10 |
| <b>13</b>  | INTERNAL HARDWARE FOR 73150 & 73300     | NA            | NA            | 6  |
| <b>14</b>  | INTERNAL HARDWARE FOR 73150 & 73300     | NA            | NA            | 6  |
| <b>15A</b> | VARIABLE SPEED MOTOR FOR 73150          | 73150MOTOR    | NA            | 1  |
| <b>15B</b> | VARIABLE SPEED MOTOR FOR 73300          | NA            | 73300MOTOR    | 1  |
| <b>16</b>  | EXTERNAL HARDWARE FOR 73150 & 73300     | NA            | NA            | 4  |
| <b>17</b>  | EXTERNAL HARDWARE FOR 73150 & 73300     | NA            | NA            | 6  |
| <b>18</b>  | DRAIN PLUG FOR 73150 & 73300            | 73300DRAIN    | 73300DRAIN    | 2  |
| <b>19</b>  | DRAIN PLUG GASKET FOR 73150 & 73300     | 73300DRAIN    | 73300DRAIN    | 2  |
| <b>20</b>  | MOUNT KIT NUT FOR 73150 & 73300         | 73300MOUNT    | 73300MOUNT    | 2  |
| <b>21</b>  | MOUNT KIT GASKET FOR 73150 & 73300      | 73300MOUNT    | 73300MOUNT    | 2  |
| <b>22</b>  | MOUNT KIT SCREWS FOR 73150 & 73300      | 73300MOUNT    | 73300MOUNT    | 2  |
| <b>23</b>  | MOUNT KIT FOOT FOR 73150 & 73300        | 73300MOUNT    | 73300MOUNT    | 1  |
| <b>24</b>  | MOUNT KIT SUPPORT FOR 73150 & 73300     | 73300MOUNT    | 73300MOUNT    | 1  |



### For 73150 Technical Specifications (1.5HP Models)

|                       |                                |
|-----------------------|--------------------------------|
| Input Voltage Nominal | 230 VAC                        |
| Input Current         | 5 Amps                         |
| Input Frequency       | 1PH, L1-L2 or L-N, 50 or 60 Hz |
| Max Input Watts       | 1150W                          |
| Max Shaft Horsepower  | 1.5 HP                         |
| Speed Range           | 1000 - 3450 RPM                |

|                                |                                 |
|--------------------------------|---------------------------------|
| Environmental Enclosure Rating | NEMA Type 3 / IPX5              |
| Ambient Condition Range        |                                 |
| Storage                        | -40°C to +60°C (-40°F to 140°F) |
| Operating                      | 0-50°C (32-122°F)               |
| Humidity                       | Relative 0-95% Non-Condensing   |

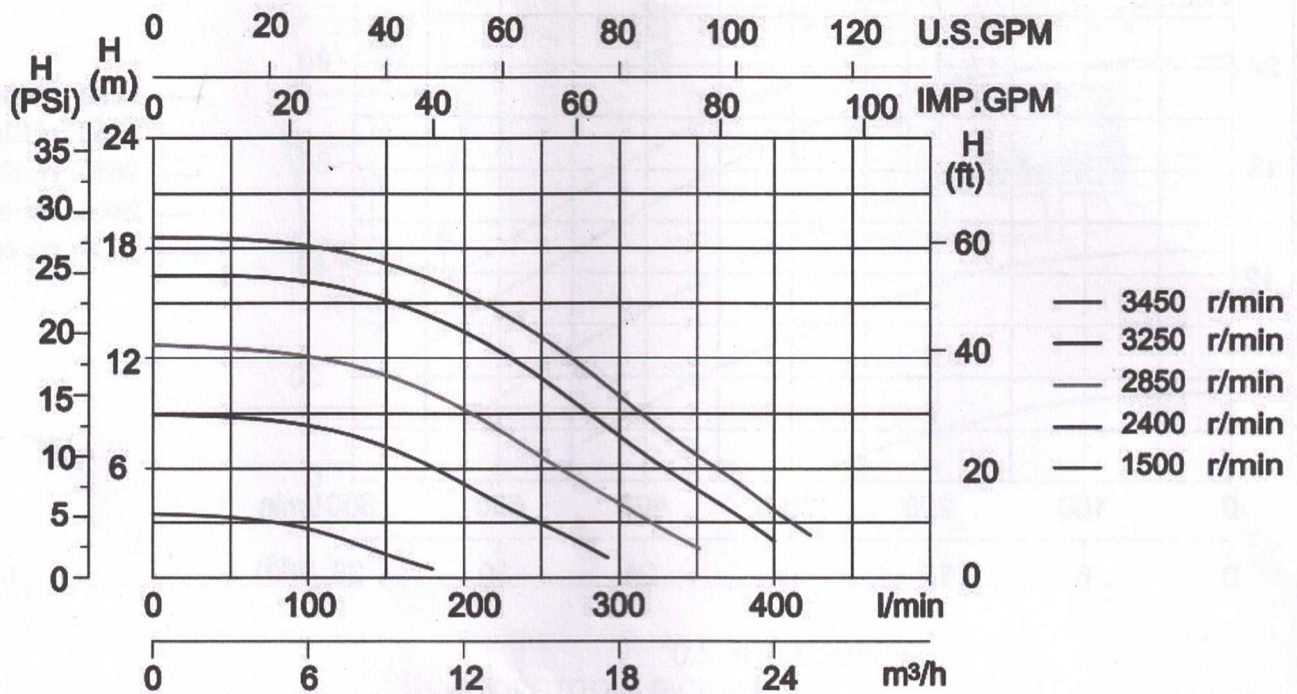

73150 1.5HP 2.0"



## For 73300 Technical Specifications (3.0HP Models)

|                       |                                |
|-----------------------|--------------------------------|
| Input Voltage Nominal | 230 VAC                        |
| Input Current         | 11Amps                         |
| Input Frequency       | 1PH, L1-L2 or L-N, 50 or 60 Hz |
| Max Input Watts       | 2500W                          |
| Max Shaft Horsepower  | 3.0 HP                         |
| Speed Range           | 1000 - 3450 RPM                |

|                                |                                 |
|--------------------------------|---------------------------------|
| Environmental Enclosure Rating | NEMA Type 3 / IPX5              |
| Ambient Condition Range        |                                 |
| Storage                        | -40°C to +60°C (-40°F to 140°F) |
| Operating                      | 0-50°C (32-122°F)               |
| Humidity                       | Relative 0-95% Non-Condensing   |

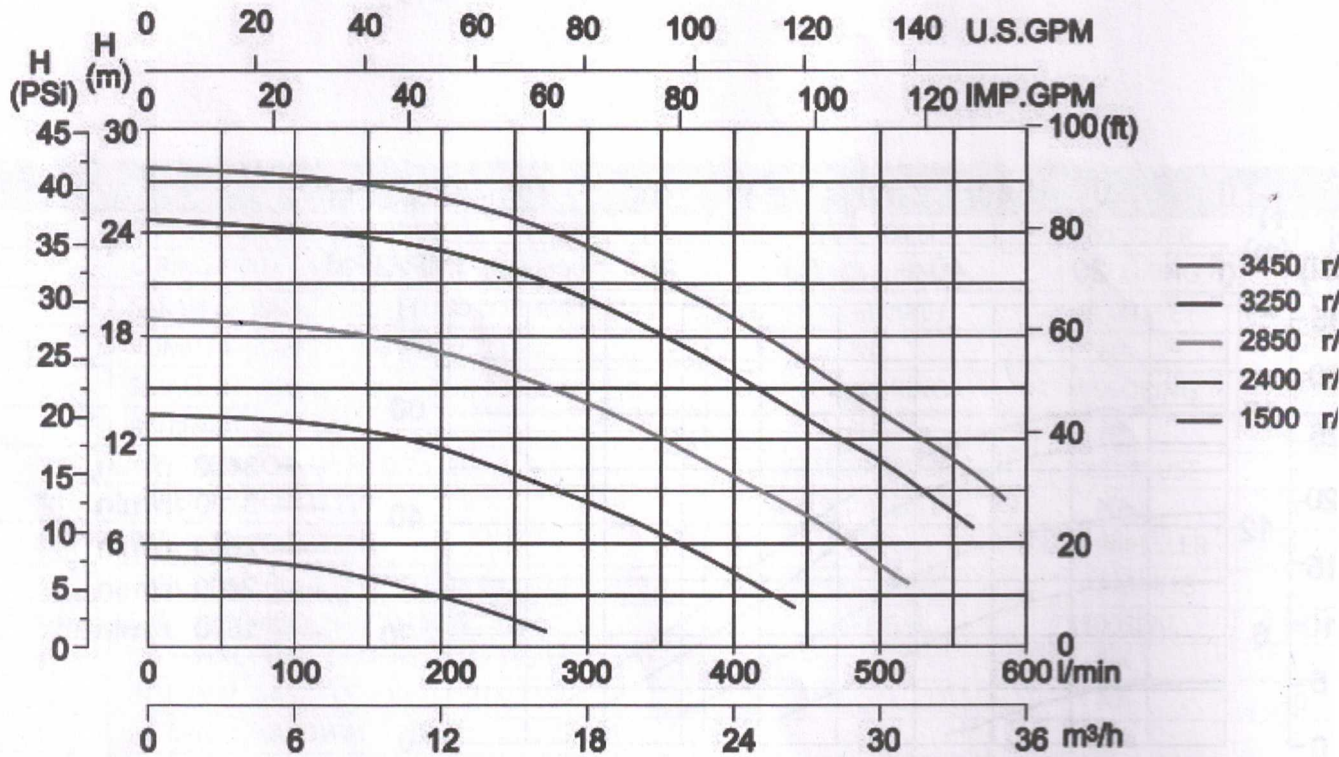

73300 3.0HP 2.0"



**For 73150/73300 Pump Dimensions (1.5HP / 3.0HP Models)**

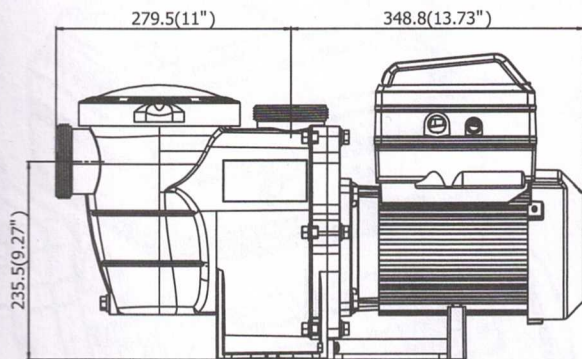
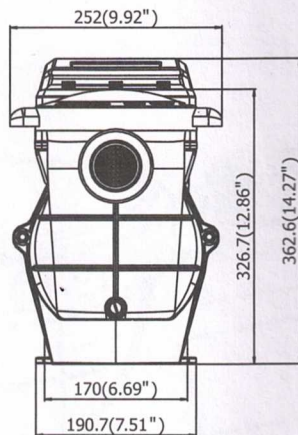
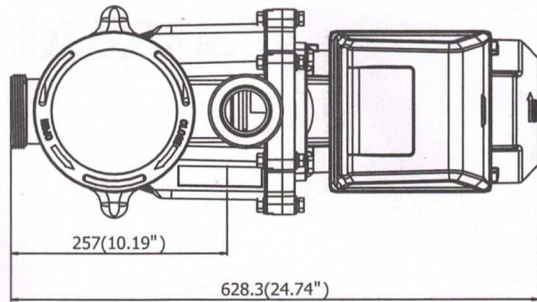
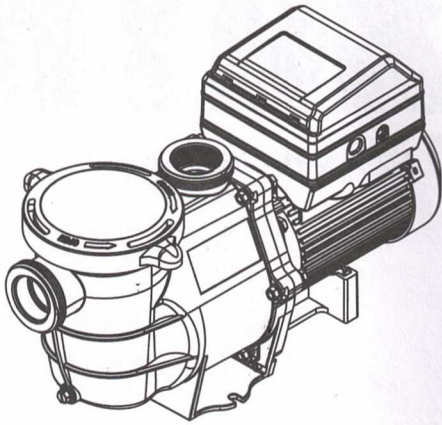

---

**HYDROTOOLS By Swimline**  
**International Leisure Products**  
 191 Rodeo Drive, Edgewood, New York 11717  
**Tel: 631.254.2155 | Fax: 631.254.2363**  
 E-mail: [info@swimlinecorp.com](mailto:info@swimlinecorp.com)  
[www.swimline.com](http://www.swimline.com)



# Q-4

# BLACK DIAMOND

## INSTRUCTION MANUAL

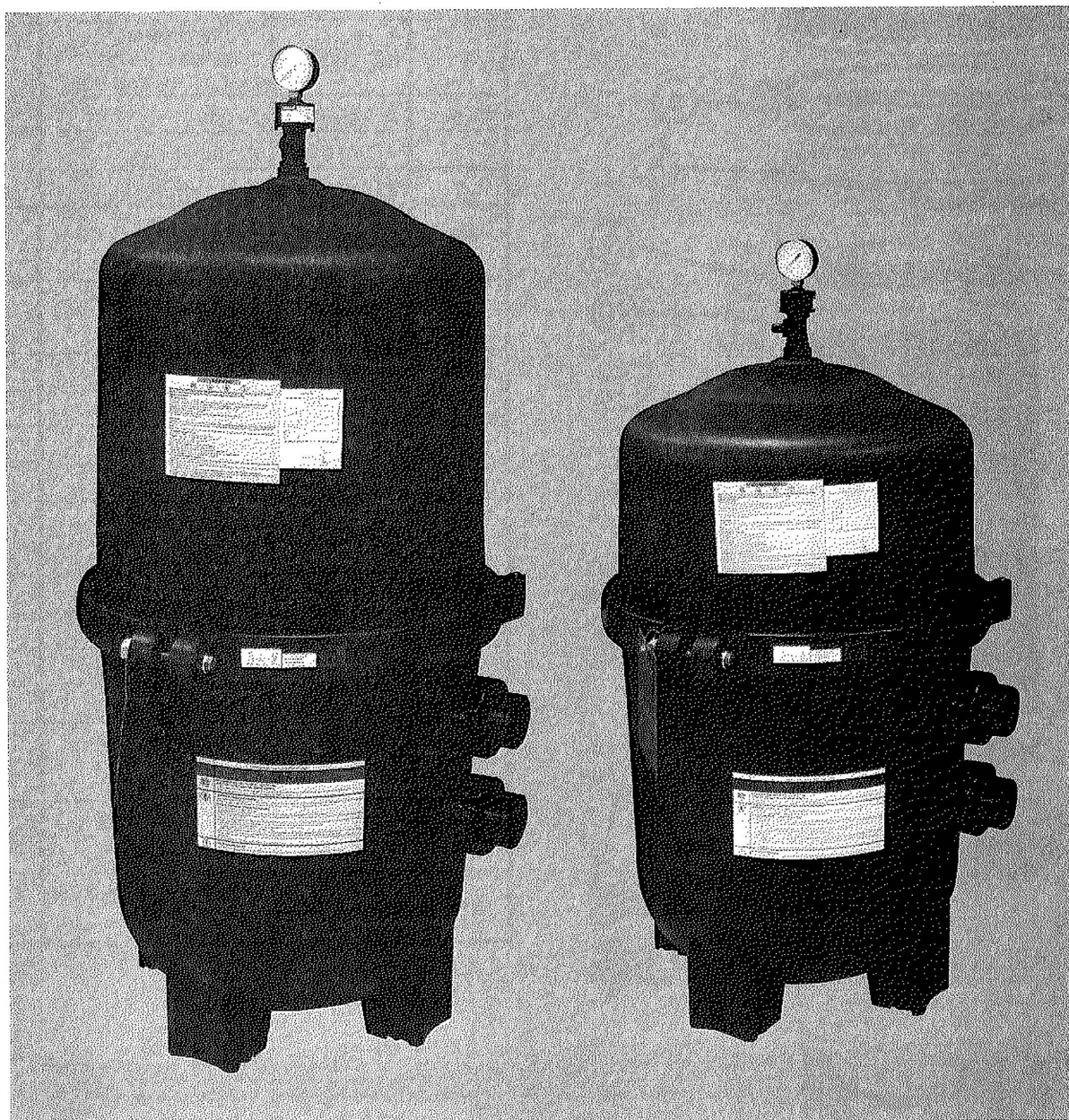

# Q-4 BLACK DIAMOND PARTS BREAKDOWN

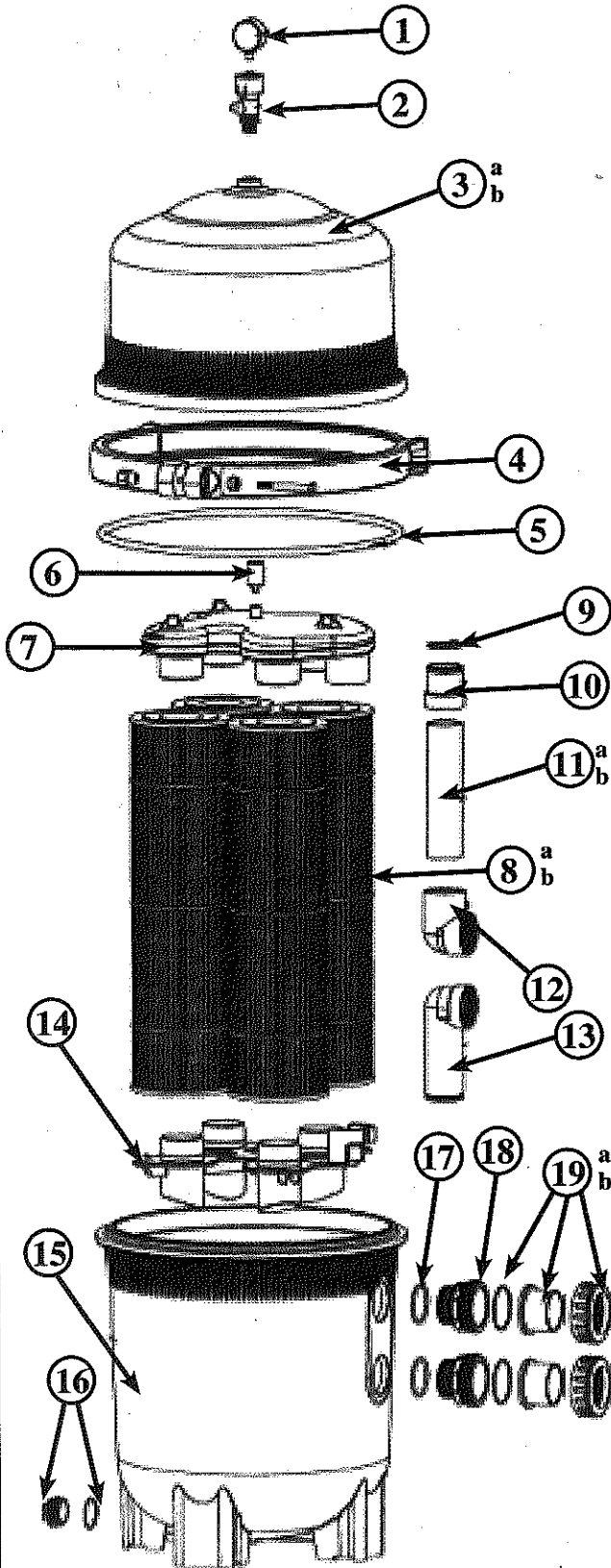

| PART # | MODEL #  | DESCRIPTION                                       | QTY |
|--------|----------|---|-----|
| 1      | AC 35874 | Press gauge                                       | 1   |
| 2      | AC 43524 | Air relief assembly                               | 1   |
| 3a     | AC 43567 | Upper filter tank for AC NK425                    | 1   |
| 3b     | AC 43575 | Upper filter tank for AC BK525                    | 1   |
| 4      | AC 43583 | Clamp system (includes clamp, clamp nut and bolt) | 1   |
| 5      | AC 43613 | O-ring  | 1   |
| 6      | AC 41939 | Air relief plug                                   | 1   |
| 7      | AC 41947 | Top manifold                                      | 1   |
| 8a     | AC 19313 | Cartridge element for AC BK425                    | 4   |
| 8b     | AC 19372 | Cartridge element for AC BK525                    | 4   |
| 9      | AC 42323 | O-ring  | 1   |
| 10     | AC 42625 | Adaptor   | 1   |
| 11a    | AC 42633 | Outlet pipe for AC BK425                          | 1   |
| 11b    | AC 42641 | Outlet pipe for AC BK525                          | 1   |
| 12     | AC 42684 | Short elbow inlet                                 | 1   |
| 13     | AC 42692 | Long elbow inlet                                  | 1   |
| 14     | AC 42706 | Bottom manifold                                   | 1   |
| 15     | AC 42714 | Lower filter body                                 | 1   |
| 16     | AC 42994 | 1-1/2" drain plug w/o-ring                        | 1   |
| 17     | AC 43133 | O-ring bulkhead                                   | 2   |
| 18     | AC 43443 | Bulkhead fitting                                  | 2   |
| 19a    | AC 43494 | Union connection kit (60 mm)                      | 2   |



## CONSUMER SAFETY INFORMATION

**Q-4 Black Diamond** is designed to provide many years of safe and reliable service. The installation, operation and maintenance instructions contained in the following pages will insure your investment in your **Black Diamond**. Throughout this manual there are safety warnings and cautions. Be sure to read and comply with all of these warnings and cautions.

### WARNING

Do not operate the **Black Diamond Filter** until you have read and understand clearly all the operating instructions and warning messages. The following instructions are intended as a guide for initial general installation and initial operation. Be advised that each installation may have unique conditions where the starting procedure can be different. Failure to follow all operating instructions and warning messages can result in severe injury, death, or property damage.

### THE Q-4 BLACK DIAMOND FILTER OPERATES UNDER HIGH PRESSURE

When any part of the filtering system is serviced, air can enter the system and become pressurized upon restart of the system. Pressurized air can cause the lid to blow off which can result in severe injury, death or property damage. To avoid this potential hazard follow these instructions:

1. Turn off the pump **BEFORE** starting any service on the filter system.
2. Open the manual air relief valve located on the top of the filter. Wait until all pressure is relieved before proceeding.
3. Whenever installing the filter tank clamp be sure to follow the Filter Clamp Instructions Precisely.
4. Once filter system service is complete follow the **System Restart Instructions** Precisely.
5. Maintain circulation system properly. Replace worn out or damaged parts immediately.
6. Be sure the filter system is properly mounted and positioned according to the instructions provided in this manual.

**Never** attempt to adjust, open or tighten any closures or lids or attempt to remove or tighten any bolts when the system is pressurized or operating. This can cause a separation or failure of filter components. Component failure will result in the instant release of pressure causing component(s) to blow off at high velocities and to travel far distances. Severe personal injury or death could occur if they were to strike a person or persons.

## **WARNING: RISK OF ELECTRICAL SHOCK/ ELECTROCUTION**

The **Black Diamond Filter System** must be installed by a qualified technician and in accordance with all electrical codes and ordinances.

Always disconnect power to the filter equipment at the circuit breaker **BEFORE** servicing the filter equipment. Make sure the disconnected circuit is tagged to prevent accidental connection. Failure to do so could result in serious injury or death due to electric shock.

Position the filter in such a way that the air relief valve will allow water to be drained away from electrical connections. Water discharged from an improperly directed valve can create an electrical hazard and cause severe personal injury as well as property damage.

## **IMPORTANT SAFETY INFORMATION**

- Have a trained pool professional perform all pressure tests.
- Do not connect the **Q-4 Black Diamond** to a Public Water System.
- All wiring, grounding and bonding of equipment must meet local and/or national electrical codes.
- A check valve installed ahead of filter system will prevent filter contents from draining back into pool.
- A check valve installed between filter and heater will prevent hot water from backing up into the filter and possibly damaging internal components.
- Piping/plumbing must conform to local/state plumbing and sanitary codes.
- Make sure all piping is adequately supported.
- Do not pressure test with an air compressor.
- Check local codes for restrictions on backwash or waste water piping.
- Trapped air in the system can create a hazardous condition. Be sure to purge all air from the system before operating, testing or servicing the equipment.



## ABOUT YOUR Q-4 BLACK DIAMOND SYSTEM

**Diatomaceous Earth DE Filters** have always been renowned for providing crystal clear pool water. Cartridge filter systems have been popular for their convenience and ease of maintenance. With the **Q-4 Black Diamond** you get the best of both worlds.

The **Q-4 Black Diamond Element Filtration System** features 4 easily accessible and removable elements. When water passes through these elements, impurities such as dirt, algae and even some forms of bacteria are filtered out, producing sparkling clear water.

The **Q-4** design dramatically increases the filter's internal surface area, giving you much greater cleaning capacity per cycle, all without an increase in the tank size. Maintaining your **Q-4 Black Diamond** could not be easier. You can choose any one of two easy methods to clean your filter. The first choice is to remove and rinse off the elements. The second and most popular choice is to remove the tank lid, open the drain plug and simply rinse the elements in place.

The **Q-4 Black Diamond** design will even save you money because water flows so efficiently through the filter that your pump will use less energy.

The combination of four **Black Diamond** elements in a single tank design means better performance and much longer filter cycles. Longer cycles mean less cleaning and maintenance. Because the **Black Diamond** elements remove the tiniest of contaminants you can be assured of clean, crystal clear water for many years to come.

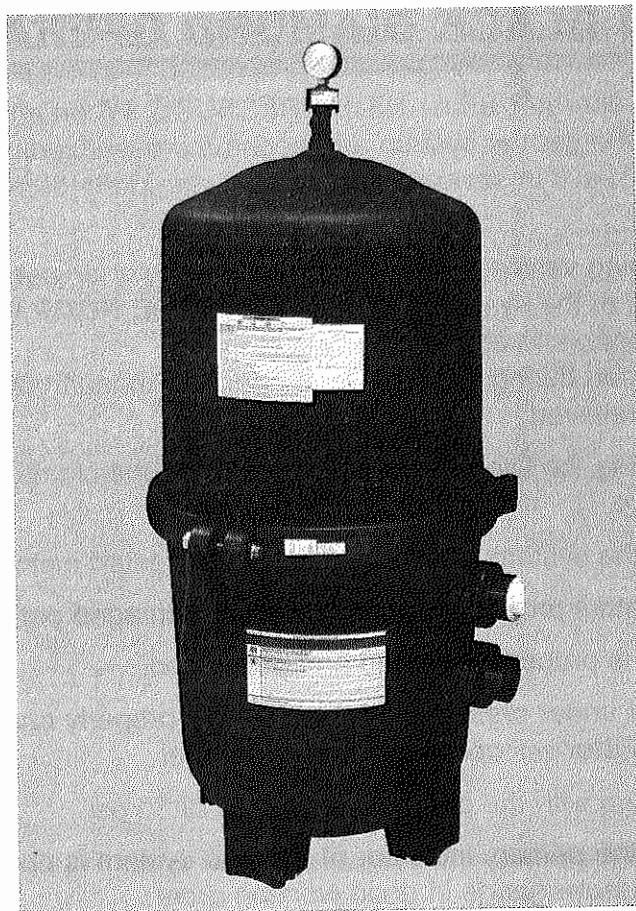

## Q-4 BLACK DIAMOND INSTALLATION

1. Your Filter should be installed on a level concrete slab or base. Take care to position the filter so the instructions, warnings and pressure gauge are visible to the operator. Keep in mind that the piping connections, valve control and drain port must be accessible for servicing, winterizing and routine maintenance.
2. Install electrical controls such as switches and timers at least 5 feet from the filter system.
3. Allow sufficient clearance around the filter tank so you can visually inspect the tank and verify the clamp is properly installed. It is advised to tap the clamp with a mallet or similar tool to make sure the clamp is uniformly loaded before tightening.
4. Allow sufficient space above the filter to allow for lid removal during cleaning and/or servicing.
5. Position the manual air relief valve to safely direct water away from the filter system and all electrical connections.
6. Make all plumbing connections in accordance with local plumbing codes.
7. Filter plumbing connections with O-Ring seals must be lubricated. Use only silicone based lubricant on the O-Rings. **DO NOT** use pipe compound, glue or pipe dope on the bulkhead connections.
8. Be sure to install the pressure gauge before use.
9. Never subject the filter to a working pressure over 50 psi, even when conducting tests.

## Q-4 BLACK DIAMOND OPERATION

1. **WARNING** – This filter operates under **HIGH PRESSURE**. When any part of the filter system is serviced, air can enter the system and become pressurized. Pressurized air can blow the lid off which can result in severe injury, death or property damage. Be sure to follow these instructions :
  - a) Before repositioning valves, assembly, disassembly, or adjustment of the clamp or any other service of the system you must **TURN THE PUMP OFF** and **SHUT OFF** any automatic controls to ensure the system is not inadvertently started during service. Then open the manual air relief valve and wait until pressure is relieved.
  - b) Whenever installing the filter clamp you must follow the clamp installation instructions. (page 7)
  - c) Once service of the system is complete follow the restart instructions exactly.
  - d) Maintain your system properly. Replace worn or damaged parts immediately.
  - e) Be sure the filter is properly mounted and positioned.
2. The **Q-4 Filter** operates under pressure. When clamped properly and operated without air in the system, the **Q-4 Filter** will operate in a safe manner.
3. Never operate the system with the pressure in excess of 50 psi.
4. The pressure gauge is the primary indicator of how the system is operating. Be sure to keep the pressure gauge in good working order.



# CLAMP INSTALLATION INSTRUCTIONS

The Clamp installation instructions must be followed **EXACTLY** to prevent the lid from blowing off during initial startup, restart or filter operation.

**BEFORE** working on the Filter System complete the following steps.

- Turn the pump off and shut off any automatic controls.
  - Open the air relief valve and wait for the pressure to be relieved.
1. Make sure the lid O-Ring is in position in the lower tank half. Press the filter lid over the lower tank half sandwiching the O-Ring between the 2 halves.
  2. Keeping the ends of the filter clamp apart, position the center of the filter clamp (the valley of the clamp) over both the upper and lower tank flanges. Carefully bring the ends together as you insert the closure bolt into the union located on the other side of the clamp assembly. (See diagram below)
  3. Place the brass nut onto threaded end of bolt. Hand tighten the nut. Keep checking the clamp for proper seating as you hand tighten the nut.
  4. Tighten the nut using a wrench. Be sure to tap around the outside of the clamp using a mallet or similar tool (do not use a metal hammer) to ensure proper seating of the clamp. Continue tapping and tightening until clamp is secure.

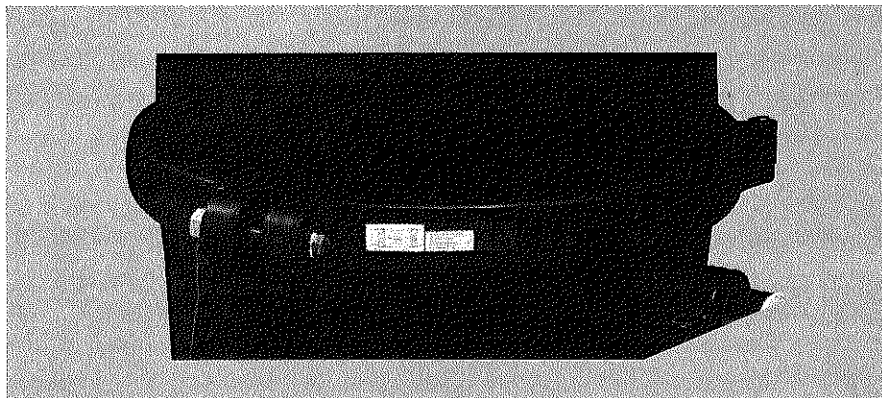

## RE-START INSTRUCTIONS

**WARNING** — This filter operates under **HIGH PRESSURE**. When any part of the filter system is serviced air can enter the system and become pressurized. Pressurized air can blow the lid off which can result in severe injury, death or property damage.

1. Open the manual air relief valve located on top of the filter tank. Opening this valve releases air trapped inside the tank.
2. Stand clear of the filter tank and start the pump.
3. Close the manual air relief valve slowly after a steady stream of water begins to flow from the air relief valve port.
4. The system is not operating properly if:
  - a) A solid stream of water does not appear from the air relief valve within 30 seconds of start up.
  - b) The pressure gauge indicates pressure inside the tank before water out flow appears.

If either condition appears, turn off the pump **IMMEDIATELY**. Open the valves in the water return line to relieve pressure and clean the air relief valve.



## **CLEANING THE Q-4 BLACK DIAMOND**

1. Turn the pump off and turn off any automatic controls.
2. Close the main drain line if your pool is so equipped.
3. Open the air relief valve to relieve any pressure in the tank.
4. Open the waste drain port located on the bottom of the tank.
5. Remove the pump's hair and lint strainer lid and clean out the basket. Replace basket and inspect lid O-Ring. Lubricate O-Ring with silicone lube if O-Ring appears dry. Replace lid onto hair and lint trap.
6. Remove the filter clamp.
7. Remove the filter lid.
8. Check the air relief valve for debris and dirt. Clean if necessary.
9. Remove the top manifold and the elements.
10. Using a garden hose without a nozzle, spray water at elements to loosen and dislodge dirt and debris. Thoroughly wash each element both inside and out.
11. Lift manifold out of tank and wash out any and all debris.
12. Wash out the inside of the tank body.
13. Check the tank gasket located on the lip of the bottom tank half. Gasket should be firmly and evenly in place. **DO NOT USE PETROLEUM LUBRICANTS ON THIS GASKET.**
14. Replace bottom manifold, the 4 elements and top manifold into the filter tank. Make sure the spring and standpipe assembly are retained on the top manifold.
15. Make sure the O-Ring is in position.
16. Replace the top lid carefully, follow the **CLAMP INSTALLATION INSTRUCTIONS.**
17. Replace drain cap.

**FOLLOW INITIAL START UP PROCEDURE**

## QUICK REFERENCE TROUBLESHOOTING

### **PROBLEM** AIR ENTERING THE FILTER SYSTEM

**CORRECTION** The following conditions in your filter system that allow air to enter and corrections for each condition:

1. Due to low water level in pool, skimmer doesn't have enough water in it and pump pulls in air along with an insufficient amount of pool water.
  - Raise water level in pool.
2. Air bubbles and/or low water level in pump's hair and lint trap.
  - Check and raise water level in pool.
  - Skimmer basket is clogged with debris – clean it out.
  - Cracked/split suction cleaner hose – replace hose.
  - Leak in pump hair and lid – lubricate lid/replace lid.
  - Leak in pump suction line – replace line.
3. Air bubbles coming out of pool return line.
  - See 1 and 2 above.
4. Air is discharged from the air relief valve when the valve is opened and the pump is running.
  - See 1 and 2 above.

### **PROBLEM** ELEMENTS LIMING UP

**CORRECTION** A stiffening of the elements' fabric caused by mineral deposits in the pool water. This is usually due to excessive deposits of magnesium, calcium or both.

1. Removal of the mineral deposits can be done by soaking the elements in a solution of 6 parts water and 1 part muriatic acid.

### **PROBLEM** SHORT FILTER CYCLES

**CORRECTION** This is normal until the water in the pool has been initially cleaned.

1. Elements may be loaded with debris, oils, etc. Clean elements thoroughly.



**PROBLEM** PRESSURE DROPS IN GAUGE

**CORRECTION** If pressure drops on pressure gauge turn off the pump and make sure any automatic controls are turned off as well. Turn the motor shaft with your fingers. If it turns freely then the pump needs to be disassembled to check the impeller for clogs. If the impeller is not clogged and the shaft is not frozen (it moves freely) then there is an obstruction in the plumbing between the pool and the pump.

**PROBLEM** PRESSURE REMAINS HIGH AFTER BACKWASHING

**CORRECTION** If pressure remains high after backwashing the filter, backwash again. If still high you need to check for Liming (see Liming – up).

**PROBLEM** DIRT/DEBRIS IS CONTINUOUSLY ENTERING THE POOL

**CORRECTION** Check the internal components of the filter.

1. Inspect the elements for any tears or holes.
2. Inspect the internal air bleed sock for any tears or improper installation.
3. Inspect the elements and make sure they are seated properly between the upper and lower manifold.

# **WARNING**

**YOUR FILTER OPERATES UNDER PRESSURE. THE FILTER MAY CAUSE SEVERE INJURY OR DEATH FROM TANK EXPLOSION.**

**YOU COULD BE SERIOUSLY INJURED OR KILLED IF YOU DO NOT FOLLOW THE INSTRUCTIONS AND WARNINGS THAT COME WITH YOUR FILTER.**

---

**IF YOUR FILTER HAS A PRESSURE RELIEF VALVE, YOU MUST USE THIS VALVE TO RELEASE ALL PRESSURE IN THE FILTER BEFORE DISASSEMBLING THE FILTER. FAILURE TO DO SO CAN RESULT IN SEVERE PERSONAL INJURY OR DEATH.**

**READ FILTER OWNERS MANUAL  
COMPLETELY BEFORE DOING  
ANYTHING TO THE FILTER**





**Blue Torrent** manufactures all of its products using cutting-edge technology with the best materials and workmanship available.

**Blue Torrent's PUMPS AND FILTERS** are warranted as follows:

## **1 YEAR LIMITED WARRANTY**

**Blue Torrent** warrants its Pumps and Filters to be free of defects in material and/or workmanship for a period of one year from the original date of purchase and/or installation.

### **WARRANTY CLAIM EXCLUSIONS:**

- Damage caused by improper installation as specified in owner's manual
- Damage caused by improper handling
- Damage due to misuse, abuse and/or failure to operate item per owner's manual
- Damage caused by improper water chemistry
- Damage caused by improper winterization of equipment
- Damage caused by not using original **Blue Torrent** replacement parts
- Damage caused by improper wiring or use of extension cords
- Accidental damage, fire, acts of God or other circumstances outside of **Blue Torrent's** control

#### **NOTE:**

- Customer must retain the original sales invoice as proof of purchase along with the installers invoice (to establish date of installation)
- Commercial facilities are not covered by warranty

Please return any and all defective items to your local authorized **Blue Torrent** dealer for inspection.

**The customer is responsible for all shipping charges to and from the nearest Factory Warranty Center. For more information. Please visit [www.btwarranty.com](http://www.btwarranty.com)**

Should a defect in material or workmanship appear the product will be repaired or replaced at our discretion. **Neither Blue Torrent nor any authorized dealer is responsible for any charges related to the installation of the new item or part.** Nor are they responsible for any incidental charges incurred including, but not limited to, water, chemicals, landscaping or any other associated expenses.